

KLM 2M-14C CIRCULAR POLARIZED ANTENNA
ASSEMBLY TEXT

April 22, 1985

KLM 2M-14C CIRCULAR POLARIZED ANTENNA

The KLM 2M-14C is a circular polarized antenna ideally suited for satellite and terrestrial communications. The characteristic pattern of the 14C is not half vertical, half horizontal, but equal in all planes within 3 dB. Circular wavefronts will exhibit a "left-hand" (LHC) or "right-hand" (RHC) "twist." The 14C is equipped with a feedpoint mounted Circularity Switcher, keyed by +9 to +15 VDC, that permits instant selection from your shack or other remote point. Only one 50 ohm feedline is needed. Electrically, the 14C has seven elements in the vertical plane and seven in the horizontal. Since each set of elements comes with its own 4:1 coax balun, the 14C can also be used as two separately fed antennas.

The "Circular" advantage...

KLM's series of circular polarized antennas were originally introduced to optimize satellite reception where circular wavefronts are generated as signals pass through the ionosphere. They have also proven to be highly useful for terrestrial communications where signals, fixed and mobile, are disturbed by buildings, movement, mountains, and/or the earth's curvature. Under these conditions, circular wavefronts are also developed and, compared with a linear polarized antenna, a user of the 14C will enjoy less flutter fading, less multipath distortion, and possibly better S/N ratios. Benefits on transmitting are similar.

Built to last, built to perform...

New design and materials help the 14C maintain good circularity and mechanical stability. The 3/16" rod parasitics are anchored firmly through the center of the boom. The dipole driven elements fold evenly around the boom. Symmetry is near-perfect. All aluminum materials use strong, weather resistant 6063-T6 or 6063-T832 alloys. All hardware is stainless steel except for U-bolts. All elements are insulated from the boom, although the driven elements can be grounded if lightning protection is desired.

Long-life coax baluns eliminate matching hassles...

The KLM 2M-14C comes complete with two 4:1 coax baluns, polarity switcher, and matching harness with SO-239 connector. Baluns and harness are constructed of coax with silver plated conductors and Teflon insulation for years of reliable service.

SPECIFICATIONS:

| | |
|----------------------------|---------------------------|
| Coverage: | 143-150 MHz (no retuning) |
| Polarization: | Circular |
| Gain : | 11 dBdC |
| Elipticity: | 3 dB max. |
| VSWR: | Better than 1.5:1 |
| Beamwidth: | 48 degrees |
| Balun(s): | 4:1 coax (2) 2KW PEP |
| Stacking Distance, H or V: | 8-10' |
| Number of Elements: | 14: 7H, 7V |
| Feed Impedance: | 50 ohms, unbalanced |
| Boom Length/Diameter: | 12'9"/1-1/2" O.D. |
| Mounting/Mast: | Center/2" Mast |
| Weight: | 7-1/2 lbs. |
| Windload: | 1.2 sq. ft. |
| Switcher, Power Rating: | 600W PEP |

ANTENNA ASSEMBLY

BEFORE YOU BEGIN

1. Select an assembly area large enough to comfortably accommodate overall antenna dimensions. A shallow box is handy for holding and sorting the smaller hardware, as is a marking pen for identifying components.
2. Some simple tools are required: a tape measure, screwdriver, and a set of spintite, socket, or end wrenches. Common nut sizes are:

5/16" = 6-32 hardware

7/16" = 1/4-20 hardware

11/32" = 8-32 hardware

1/2" = 5/16-18 hardware

To avoid damage to antenna components, be aware that most hardware needs only be moderately hand-tightened with screwdriver or spintite to be secure. When using tools with mechanical leverage, such as socket or end wrenches, care must be taken not to over-torque nuts and damage components.

3. Thoroughly unpack shipping box and check components and hardware against the Parts List. If there is a difference, look for a "Factory Update/Change" sheet accompanying the assembly instructions prior to contacting your KLM dealer or the factory.

BEFORE YOU BEGIN - cont'd

- For the best results, use the pictorials to identify the various antenna components before you begin assembly.

BOOM ASSEMBLY

- The end of each boom section to be assembled is marked with a letter in felt pen. Assemble boom sections matching like letters ("A" to "A", etc.) and aligning screw holes. Each joint requires two sets of 8-32 x 1-3/4" screws, lock washers and nuts. Hand-tighten nuts securely. Section placement and length will follow the sketch below:

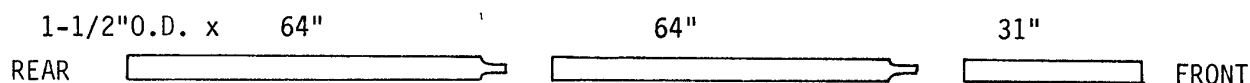

- Mount 1" steel clip to right side of boom (when viewed from rear) using the hole 25-1/2" from rear. Secure with 6-32 x 1-3/4" hardware.

DRIVEN ELEMENT ASSEMBLY

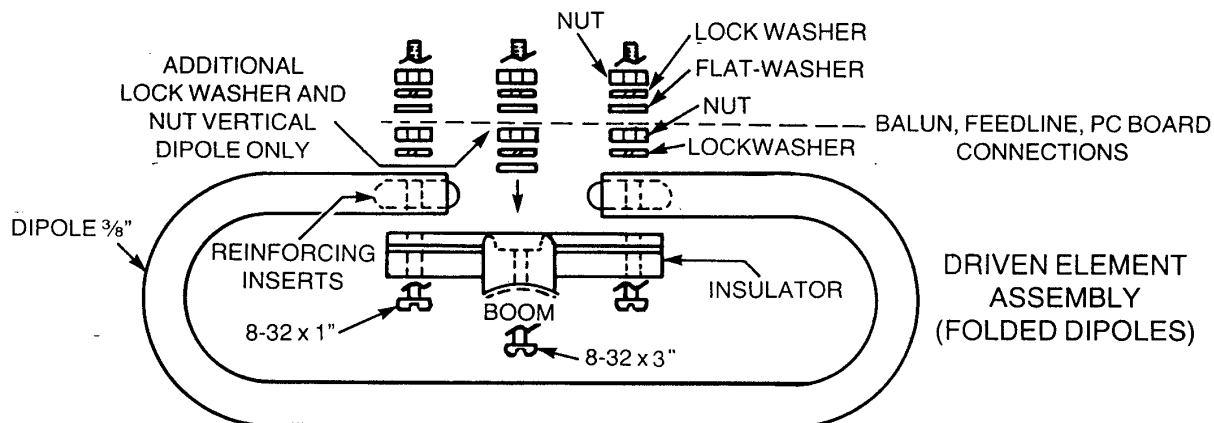

DRIVEN ELEMENT ASSEMBLY - cont'd

1. Select one of the folded dipoles and insert the reinforcing inserts into the tubing ends, aligning the holes.
2. Mount the dipole element to the insulator using the 8-32 x 1" screws, nuts, and lock washers. See the sketch above for the correct hardware arrangement. Repeat Steps 1 and 2 for other dipole assembly.
3. (Refer to assembly pictorial) Mount the vertical dipole first, element to the front, insulator mounting block to the rear. Orient insulator on same side as 1" clip. Insert 8-32 x 3" mounting screw from the opposite side of the boom. Place a #8 flat washer, lock washer and nut on the screw and hand-tighten.

Mount the horizontal dipole in the same way, with the insulator oriented on the underside of boom. Add an additional lock washer and nut to the mounting screw to provide an even platform for mounting the PC board.

4. Place the PC board onto the horizontal dipole studs first, then add the coax balun leads (lugs on feedpoints, strap on mounting stud). Secure with three sets of 8-32 flat washers, lock washers and nuts.
5. Place the SO-239 case into the clip, connector facing rear. Place the other coax balun on the vertical dipole studs, then add the coax lead from the SO-239 case. Place braid strap on the mounting stud. For unkeyed RHC (right-hand circularity) connect the center lead to the UPPER feedpoint stud. for unkeyed LHC (left-hand) connect the center lead to the LOWER feedpoint stud. Secure coax leads with harness ties as shown in Assembly Pictorial.

DIRECTOR/REFLECTOR ELEMENT MOUNTING (parasitics)

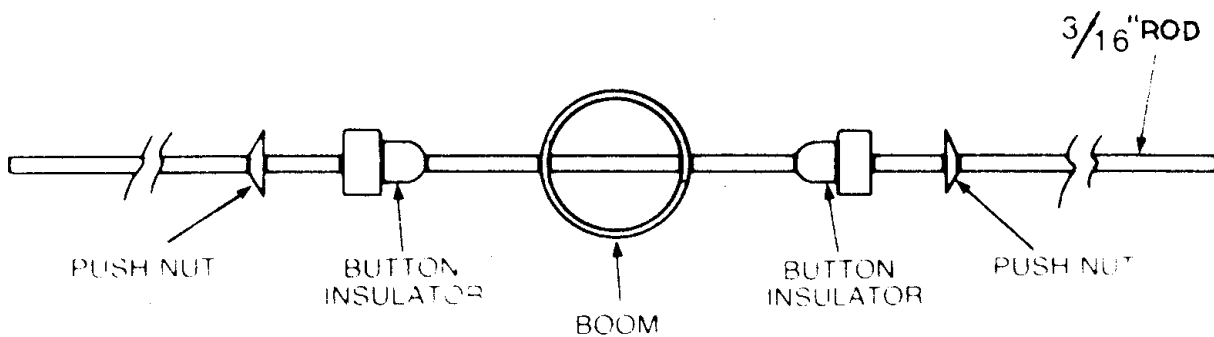

ROD ELEMENT INSULATOR
ARRANGEMENT

Separate the parasitic elements into two groups of vertical and horizontal elements. Install one group (vertical or horizontal) at a time.

Locate the longest 3/16" diameter element (reflector). Slide on one of the "button" mounting insulators, small end first. Push the insulator to the element balance point. **DON'T WORRY ABOUT THE EXACT LOCATION AT THIS POINT.** Repeat this operation for each of the remaining rod elements.

Pick up all the rod elements and settle them in your grasp on a flat smooth surface. Starting with the longest rod, insert it through the end hole in the boom near the driven elements. Next, move to the hole directly in front of the driven elements and insert the next longest element. Continue inserting the next longest rod director in the next hole, and the next, and the next, until all the rod directors are in place.

Now return to the reflector and slide on the second button insulator from the opposite side of the boom. Visually center the element in the boom. Consult the antenna Dimension Sheet and, using a tape measure, set the element position so the element is centered in the boom. **THIS CENTERING OPERATION IS VERY CRITICAL FOR PROPER PERFORMANCE OF THE ANTENNA.**

Move the next rod director and repeat the second button insulator installation and centering operation. Continue until each rod director is fully mounted and centered.

Return to the reflector now and install the element keeper washers on each side. **BEFORE PUSHING THEM TIGHTLY UP AGAINST THE BUTTON INSULATORS, CHECK FOR PROPER CENTERING ONE MORE TIME.** Proceed by adding the keeper washers to the rest of the rod directors until all have been center-checked and have the keepers installed.

DIMENSION SHEET
KLM 2M-14C

ELEMENT SPACING - FEET/INCHES FROM
BOOM REAR:

ELEMENT LENGTHS IN INCHES:

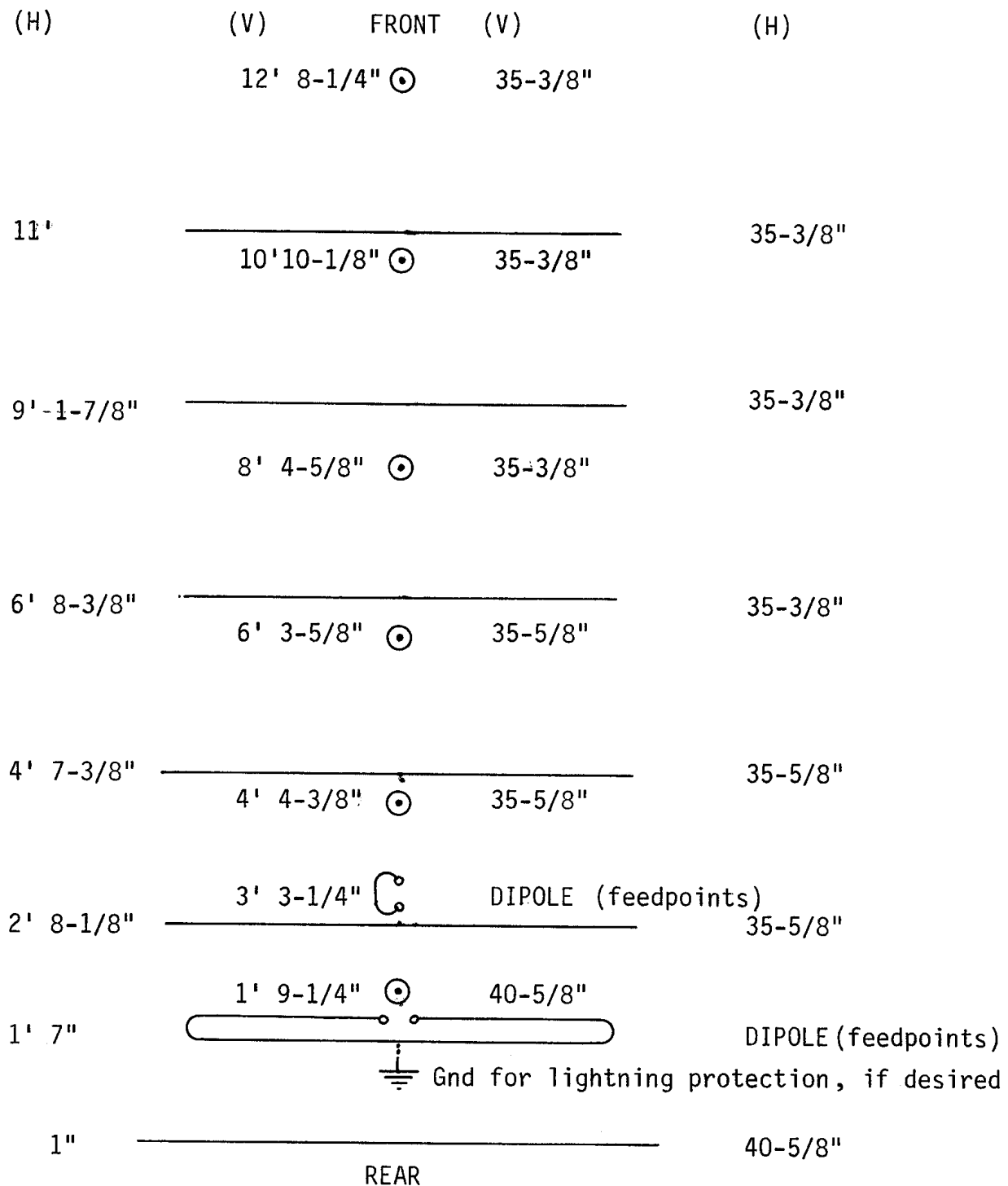

X X = FEEDPOINTS. For 50 ohm feedline, each set of feedpoints has an RG-142 4:1 Coax Balun rated at 2 KW PEP.

Use a tape measure and the Dimension Sheet to check all elements for correct length and placement. Use the Assembly Pictorial and other sketches to check for correct assembly of dipoles, feed harness and other hardware. Check all nuts and screws for tightness.

INSTALLATION

1. Circularity of the 14C can be reversed when +9 to +15 VDC is applied to the relay through the phono jack mounted on the PC board. Prepare the DC supply lines (22 AWG or larger) with a male phono plug, + lead to center pin - lead to shell.
2. Route the DC line through the horizontal dipole, from the rear, and plug into PC board jack. Route the feedline the same way and connect to the SO-239 connector. Use a harness tie to secure both cable to boom just forward of the dipole. Secure again about 4" behind the dipole. This is the takeoff point -refer to the assembly pictorial. From this point, tape or strap feedline and DC line together to aid in routing.
3. Attach the 4" x 6" boom-to-mast plate as close to the balance point as possible. Keep plate at least 1/2" from elements. Secure with 1-1/2" U-bolts.
4. The 14C, like any antenna with vertical elements, **MUST BE MOUNTED ON A NON-CONDUCTIVE MAST**. Thick wall fiberglass tubing is ideal (available from KLM) although hardwood rod and PVC pipe of suitable strength have also been used. Use of a metal mast will adversely affect VSWR, gain, pattern, etc., acting just like an untuned element in the wrong place. Mount with rear element horizontal.
5. After the 14C is installed on the mast, route feedline/DC line off the boom in a large loop and reattach to the mast at least 6" below the lowest element tip. If you have another antenna mounted below the 14C, route the lines down to the boom of the lower antenna and then back to the mast. This reduces the length of unsupported line and improves the appearance of the installation. See the sketches below:

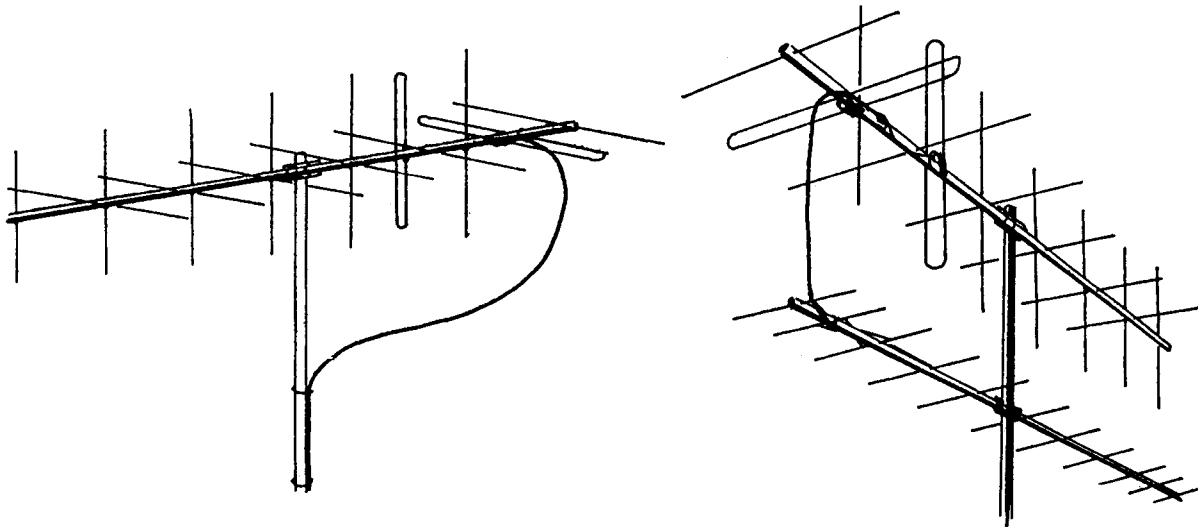

HINTS AND TIPS

1. The 14C may also be used as two separately fed antennas. Remove the polarity switcher board and matching harness. Re-install the balun to the horizontal feedpoints. Run separate 50 ohm feedlines. Attach solder lugs to braid and center conductor. Attach Gnd/Braid lug to insulator mounting screw stud. Attach center conductor lug to either of the feedpoint studs.
2. Stacking with other antennas: Keep 14C at least 80" from 2 meter antennas, 40" from non-resonant antennas. Keep element tips at least 1/4 wave (20" @ 144 MHz) from other antenna element tips or metallic objects.
3. Always use high quality coax for your feedline(s) and eliminate one possible source of losses, mismatches, and distorted patterns. Belden 8214 or Times FM-8 are recommended.

**KLM 2M-14C
HARDWARE ARRANGEMENT**

NOTE: Feedline connections shown provide AMSAT RHC polarization with relay de-energized.

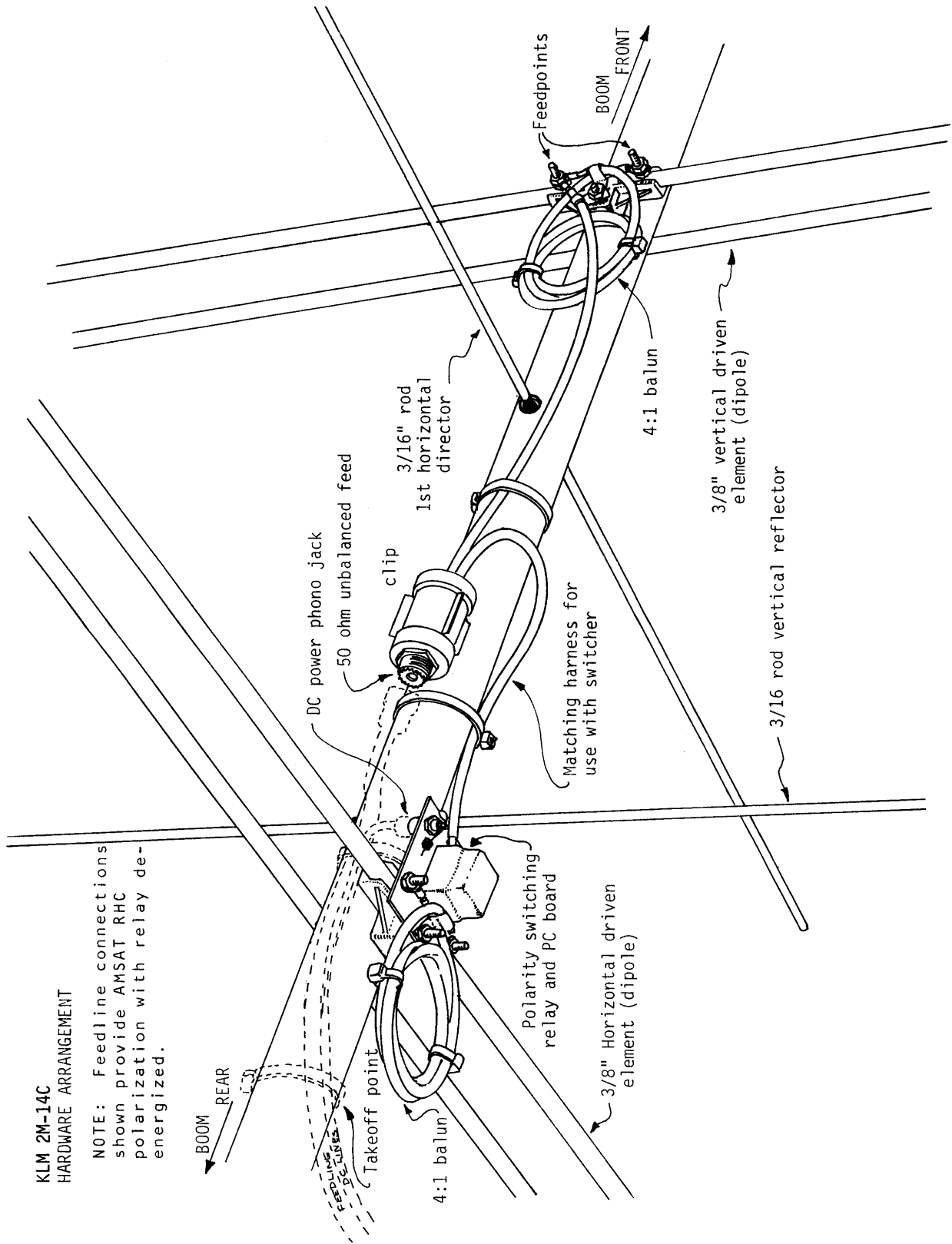

PARTS LIST

| PART DESCRIPTION | KLM PART NUMBER | QUANTITY |
|------------------------------------|-----------------|----------|
| Swaged Tube, 1-1/2" O.D. x 64" | | 2 |
| Straight Tube, 1-1/2" O.D. x 31" | | 1 |
| Dipole Element, 3/8" O.D. x 72" | | 2 |
| Element, 3/16" O.D. x 40-5/8" | | 2 |
| Element, 3/16" O.D. x 35-5/8" | | 4 |
| Element, 3/16" O.D. x 35-3/8" | | 6 |
| Boom-to-Mast Plate, 4" x 6" x 1/8" | | 1 |
| Phasing Coupling, CS-14C | | 1 |
| Harness | | |
| Coax Balun | | 2 |
| Assembly Manual | 84041 | 1 |
| Hardware Bag #1 | | 1 |
| U-Bolts and Cradles, 1-1/2" | 28401 | 4 |
| Hardware Bag #2 | | 1 |
| Screws, 6-32 x 1-3/4" | 28008 | 1 |
| Nut, 6-32 | 28201 | 1 |
| Lock washer, #6 | 28351 | 1 |
| Screws, 8-32 x 1" | 28031 | 4 |
| Screws, 8-32 x 1-3/4" | 28016 | 4 |
| Screws, 8-32 x 3" | 28020 | 2 |
| Nuts, 8-32 | 28202 | 18 |
| Flat washers, #8 | 28302 | 8 |
| Lock washers, #8 | 28352 | 18 |
| Nuts, 5/16-18 | 28206 | 8 |
| Lock washers, 5/16" | 28356 | 8 |
| Large Nylon Ties | 66119 | 8 |
| Type II Insulator, 3/8" x 1-1/2" | 66114 | 2 |
| Push nuts, 3/16" | 28218 | 28 |
| Peanuts | 66117 | 4 |
| Boom Plugs, 1-1/2" | 66117 | 2 |
| Button Insulator | 66125 | 24 |

K4XL's **BAMA**

This manual is provided **FREE OF CHARGE** from the "BoatAnchor Manual Archive" as a service to the Boatanchor community.

It was uploaded by someone who wanted to help you repair and maintain your equipment.

If you paid anyone other than BAMA for this manual, you paid someone who is making a profit from the free labor of others without asking their permission.

You may pass on copies of this manual to anyone who needs it. But do it without charge.

Thousands of files are available without charge from BAMA. Visit us at <http://bama.sbc.edu>