

Another Way to Look at Vertical Antennas

*What's the difference between a dipole and a vertical?
Maybe not as much as you think. Come along
and try another point of view.*

By Rudy Severns, N6LF



The grounded vertical is one of the earliest radio antennas, well known to Marconi and widely used today by amateurs, particularly for 80 and 160 meters. VHF verticals with “ground planes” are also popular. Traditionally, ground has been viewed as an integral part of the antenna—in effect supplying the “missing” part of the antenna, since, at low frequencies at least, the vertical portion of the antenna is usually less than $\lambda/2$. Even when the antenna is not grounded, but raised above ground, we still use the terms “elevated ground system,” “counterpoise ground,”

“ground plane” and so on. In this view, we retain the concept that ground is an integral part of the antenna and an ungrounded vertical must have some structure that replaces the “real” ground. While this conceptual framework has served us well for over 100 years, it tends to limit our thinking to more traditional solutions. A change in viewpoint exposes useful variations, better suited for particular applications.

The traditional view, stemming largely from the work of Brown, Lewis and Epstein¹ in the 1930s, is that a $\lambda/4$ vertical, with a ground system of 100 or more long radials, is the ideal—anything else is an inferior compromise.

Recent work,^{2,3} using primarily NEC modeling, has indicated that el-

evated ground systems with only 4 to 8 $\lambda/4$ radials can be very competitive with the more-traditional 120-buried-radial antenna, although that is the subject of some controversy, due to the difficulties experienced with experimental verification. There is even the heresy that radials as short as $\lambda/8$ may be only marginally less effective than full $\lambda/4$ radials and have significant practical advantages. Elevated-radial systems have their own drawbacks, such as (1) nonuniform radial currents,⁴ which lead to asymmetrical patterns and perhaps increased loss, and (2) the need for an isolation choke at the feed point. A network of wires, arranged in a circle $\lambda/2$ in diameter and suspended above ground, may be more trouble than simply burying the wires. There has been considerable

discussion—regarding traditional $\lambda/4$ radials used in elevated ground systems—as to whether these are a poor choice or not and whether other arrangements may be superior.^{4, 5, 6, 7, 8}

Because most amateurs are severely limited by available space and the cost of towers and extensive ground systems, the traditional buried-radial or even the elevated $\lambda/4$ -radial systems are frequently infeasible. What is needed is a wide range of other choices for the antenna structure from which to choose the best compromise for a given situation. Obviously, the final design should sacrifice as little performance as possible.

An alternate way to look at verticals has been suggested by Moxon (see Note 5) and others:

1. The antenna is a shortened (less than $\lambda/2$) vertical dipole with loading. The loading may be symmetrical or asymmetrical, lumped or distributed, inductive or capacitive, or a combination of all of these. Usually, the loading contributes little to the radiation, although some loading structures may radiate.

2. Ground is *not* part of the antenna. However, the interaction between ground and the antenna—and the loss in the ground—must certainly be taken into account. This includes both near and far fields.

This view can be maintained even when a portion (or all!) of the antenna is buried.

At first glance, this seems a trivial conceptual change. Nonetheless, looking at a vertical as a short, loaded di-

pole in proximity to ground—rather than as a grounded monopole—opens possibilities not usually considered with the more traditional point of view. For example, with a full $\lambda/4$ vertical, one would not normally consider adding a top hat for loading. However, in so doing, the diameter of an elevated ground system at the base of the antenna can be drastically reduced, seemingly out of proportion to the size of the top loading hat. This can be a very real advantage by reducing the footprint of the antenna. A shortened, horizontal dipole antenna with a hat at each end is very well known; it draws little comment. Nevertheless, vertically orienting the antenna and manipulating the end-loading devices to suit the application is not so common—although the antennas are conceptually identical!

Loaded Dipoles in Free Space

One of the simplest ways to resonate a shortened dipole (less than $\lambda/2$) is to add capacitive elements or “hats” at the ends, as shown in Fig 1. As indicated, the feed point may be anywhere along the radiating portion of the antenna. Fig 1 shows symmetrical end loading. Fig 2 shows extreme asymmetrical loading, where only one capacitive loading structure is used. This is, of course, the familiar ground-plane antenna being viewed as an asymmetrical dipole. Actual antennas can vary between these two extremes, since they incorporate various sizes and geometries of loading hats to suit particular applications.

When the vertical portion of the

antenna, h , is less than $\lambda/4$, top loading is commonly employed. However, top loading is usually not considered when $h \geq \lambda/4$. This may be due to our past view that we need an extensive set of buried radials, or equivalently, an elevated system of $\lambda/4$ radials. For a $\lambda/4$ vertical, the diameter of the radial system will be $\approx \lambda/2$, changing only slowly as the number of radials is varied. On the other hand, if we lengthen the vertical section beyond $\lambda/4$, add some top loading or even some inductive loading, the diameter of the bottom radial structure drops rapidly.

A simple example illustrating this point is given in Figs 3 and 4. Fig 3 shows an asymmetrical $\lambda/4$ dipole with two radials (L1 and L2) at each end. L2 is varied from zero to 22.3 feet, and L1 is readjusted, as needed, to resonate the antenna at 3.790 MHz.

Clearly, adding even a small amount of top loading (L2) greatly reduces the length of the bottom radials (L1), and consequently the land area required

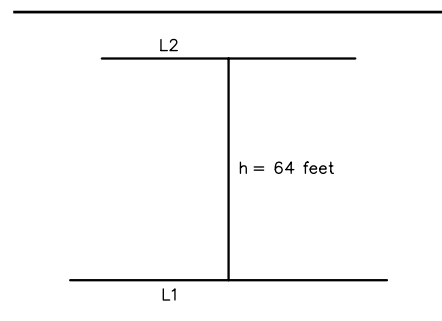

Fig 3—Asymmetric two-radial dipole. $F_R = 3.790$ MHz.

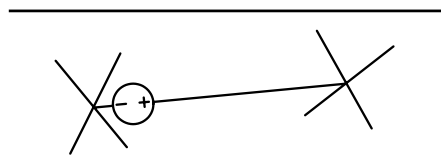

Fig 1—Short loaded dipole.

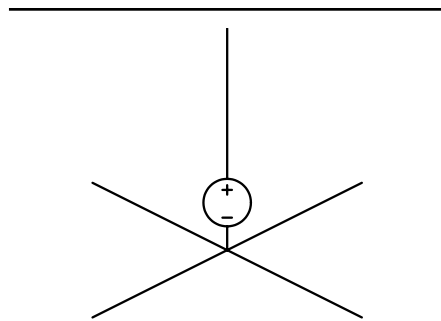

Fig 2—Asymmetrical dipole.

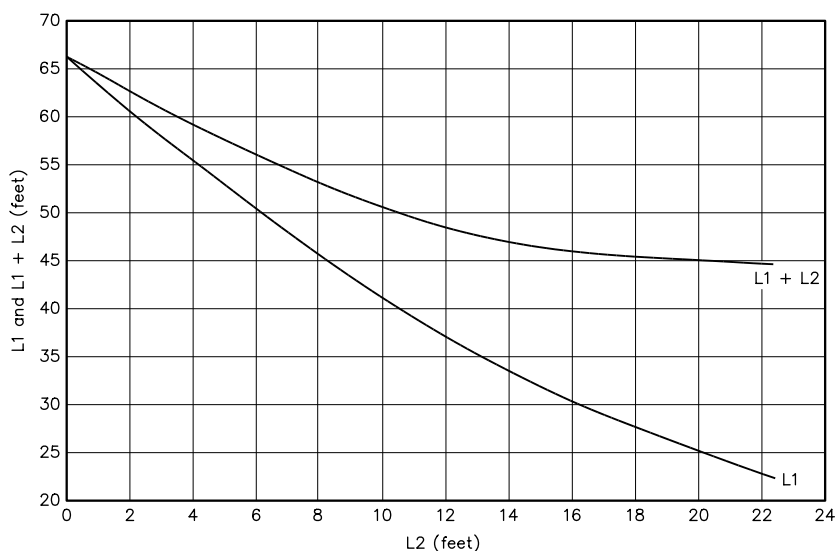

Fig 4—Effect of top loading on radial length.

for installation. This is a matter of considerable practical importance to those with restricted space in which to erect an antenna. With somewhat more complex loading elements, the footprint can be reduced even further.

In addition to greatly reducing the length of the radials, a number of other things happen during the above exercise:

1. With only two radials and no top loading, the radiation pattern varies with azimuth by about 0.7 dB, making the pattern slightly oval. This pattern asymmetry essentially disappears as the radials (L1) are shortened with top loading (L2).

2. When placed over ground, the currents in individual $\lambda/4$ radials are rarely equal. This can lead to asymmetric patterns and increased loss. The current asymmetry rapidly decreases as the radials are shortened.

3. The peak gain, and the angle at which it occurs, changes relatively little as top loading is added and bottom radials shortened while keeping the vertical section the same length.

4. Small amounts of inductive loading could also be used to supplement or even replace the top loading. As long as the vertical section is close to $\lambda/4$, the radial lengths can be reduced to $\lambda/8$ without seriously increasing losses.

Modeling Issues

The realization that everything—from the length of the radiator to the type and distribution of loading—is a potential variable that may be adjusted to achieve specific ends, is a very liberating idea. Unfortunately, it brings its own set of problems. Which variations are best for a given application? A multitude of questions arise when judging any particular variation.

The large number of possibilities and questions cannot be dealt with analytically, at least beyond an elementary level. The only practical way to deal with the many variables is to systematically explore the possibilities with *NEC*, *MININEC* or other CAD modeling software. Yet, even that is not a simple matter. Each modeling program has particular strengths and weaknesses that affect its use for this problem. The bottom portion of a vertical for 80 or 160 meters is usually very close to ground (less than 0.05λ). For these applications, the modeling software should implement the Norton-Sommerfeld ground and properly model the current distribution in the lower part of the antenna as modified by induced ground currents.

Only *NEC 2* and *4* do this. Of course, if the lower part of the antenna is buried in the ground, only *NEC 4* is suitable.

Loading structures may consist of a web of wires with multiple wires at each junction, perhaps of different diameters, and with small angles (less than 90°) between adjacent wires attached to the same node. *MININEC*-based software can model multiple acute angles if segment tapering is used, but if many wires are used in the structure, the number of segments becomes quite large. *MININEC* Broadcast Professional, using a different segment-current distribution, does an even better job without the need for tapering. However, both of these programs do not model the interaction properly for very low antennas over real ground. *NEC 2* can model the ground effects correctly, but may not handle the multiple small angles properly, especially if different diameter conductors are connected. *NEC 4* is much better in this respect, but is not widely used by amateurs because of its expense.

Real grounds are frequently stratified beginning only a few feet down. On 160 meters, the skin depth is of the order of 15 to 20 feet, and it is common to have several layers with different electrical properties over that distance. Even in homogeneous ground, the effect of rain and subsequent drying creates a varying conductivity profile. None of the presently available software addresses this problem. The validity of *NEC 2* or *4* modeling for ground has been questioned because of differences between experimental measurements and predictions made by modeling. This is a critical issue. If *NEC* is fundamentally deficient with regard to ground modeling, then the comparisons to date between buried-radial and elevated-radial systems are invalid. That includes the work reported in this article! On the other hand, *NEC* modeling may be fine, but the problem lies with the highly variable nature of real ground. This is particularly so down to depths of 15 to 20 feet, which cannot be simulated with *NEC*, but that could greatly modify experimental results. Some support for this view comes from experimental work at higher frequencies. There the skin depth is much less, and modeling predictions are in much better agreement with experiments.

The presently available software, while a remarkable achievement, is not totally satisfactory to fully exploit the possibilities. The suggested point of view brings this out. A great deal of

care must be used when modeling a vertical with a complex loading system near ground.

A Design Example

The advantages of employing a different conceptual approach can be illustrated using the 160-meter vertical used at N6LF, where an effective antenna was built on a very difficult site at low cost.

The site is on a narrow ridge—approximately 60 feet wide at the top—in a forest. There is no possibility of installing an extensive buried radial system because of the dense forest, heavy underbrush, steep slopes and very large old-growth stumps. Even an elevated system of normal size, about 260 feet in diameter, is not practical.

A support for the antenna was constructed from three Douglas fir trees, fastened together to form an A frame (see the sidebar “A Large A-Frame Mast, Inexpensively” for details). This resulted in a support 135 feet high. Allowing eight feet from the bottom of the antenna to ground and a few feet of slack at the top for sway in high winds, the final vertical length is 120 feet—very close to $\lambda/4$. Because the antenna is located over 700 feet from the shack, 75 Ω Hardline coax (a freebie from the local CATV company) is used for the transmission line. The antenna was designed to have a 75- Ω feed-point impedance to match the transmission line. The feed-point impedance at the junction of the lower hat and the vertical wire was manipulated by adjusting the relative sizes of the bottom-hat and top-loading wires. Alternately, I could have used a larger hat on the bottom and moved the feed point up into the vertical part of the antenna, but this was not done because of the limited space available for the bottom hat. I also tried some inductive loading at the base and at the junction of the top-loading wires. Relatively small amounts of inductive loading—with very little additional loss—would further reduce the size of either or both of the capacitive loading elements. I did not keep any inductive loading because sufficient space was available for the arrangement shown.

The final antenna is shown in Fig 5. There are four radials at the bottom, connected by a skirt wire at the ends. The diameter of this bottom-loading structure is only 40 feet, compared with 260 feet for normal $\lambda/4$ radials. Two sloping wires are used for loading at the top. A sloped top hat may not be optimal when compared to horizontal

wires: The radiation resistance is somewhat lower. Nevertheless, this arrangement is very simple and allows the antenna to be tuned by changing the angle of the wires with the vertical portion of the antenna. This can be done from ground level by shifting the attachment points for the guy lines supporting the sloping wires.

Christman's comparison (see Note 2) between a 120-buried-radial vertical and an elevated four-radial vertical (both with $h = \lambda/4$) indicates that the gain and radiation-pattern differences between the antennas are quite small: 0.35 dB for peak gain, 1° for peak gain angle. Because the difference is so small, I have chosen to use the four-radial elevated antenna as the reference antenna, since it is much easier to model than a complete 120-buried-radial antenna.

Using *NEC4D* for modeling, radiation-patterns for a four-radial ground-plane antenna and this antenna were compared. The result is presented in Fig 6. The model assumes ground of average electrical characteristics under the antenna ($\sigma = 0.005 \text{ S/m}$; $\epsilon = 13$). The wire used was #13 copper, and its loss was included in the modeling. The price paid for drastically reducing the diameter of the bottom loading structure is a peak-gain reduction of 0.5 dB. This is a fair trade for dramatically easing the installation of the lower loading element because 0.5 dB will probably not be detectable in actual operation. In the real world, where full-size ($\lambda/4$) radials very likely have varying currents (see Notes 4 and 8), the smaller antenna may not, in fact, be inferior at all. In this particular example, full-size radials would need to zigzag down a steep hillside at various angles. It is very doubtful they

would have been any better than the small hat that was adopted.

Any antenna with an elevated radial system needs an isolation choke (common-mode choke, or *balun*, if you prefer) on the transmission line near the feed point. One effect of moving the loading from the bottom to the top of the antenna is to increase the potential between the feed point and ground. This requires more inductance in the isolation choke to properly decouple the transmission line. For this application, I happened to have a roll of $1/2$ -inch Hardline. The roll was about two feet in diameter, so I simply expanded it into a coil three feet long and two feet in diameter with a simple wood framework to hold it in place. Fig 7 is a photo of this king-sized decoupling choke.

The result was a choke with $350 \mu\text{H}$ of inductance ($4 \text{ k}\Omega$ at 1.840 MHz). When this value of inductance was placed in the model with a buried transmission line, there was still some interaction; resonance was displaced downward. This was also found true on the actual antenna. This illustrates

one of the drawbacks of very small bottom-loading structures: A choke with enough inductance to avoid interaction may not be practical, at least on 160 meters. Since the current in the choke is relatively small, additional losses due to ground currents will not be very large. The Q of the choke, however, must be high to limit losses in the choke itself.

The monster balun shown here is extreme and not required. A much smaller choke could be used. The large structure was used because it was actually very convenient with the materials on hand.

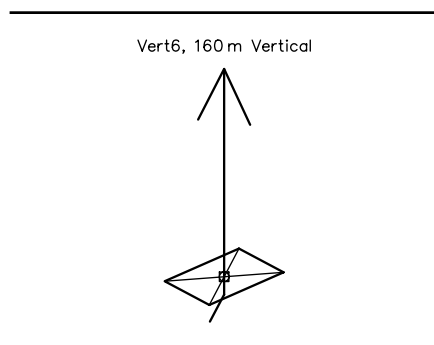

Fig 5—Antenna configuration.



Fig 7—Rudy and the “small” decoupling choke.

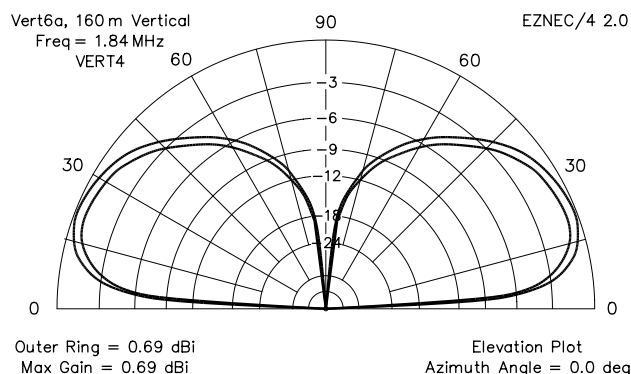

Fig 6—Comparative radiation pattern.

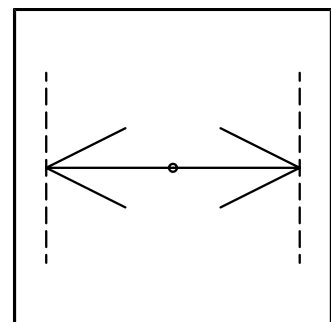

Fig 8—Flat versus drooping loading wires.

A Large A-Frame Mast, Inexpensively

A $\lambda/4$ vertical is about 70 feet tall on 80 meters, and 130 feet on 160 meters. Getting this height with a tower can be expensive. I needed a less-expensive alternative. In the Pacific Northwest, fir trees with heights greater than 100 feet are common, and can usually be purchased locally and inexpensively if they are not already growing on your property. In the southeastern US, there are extensive pine forests which, while not typically as tall as the firs, can be used in the same way. I have many tall Douglas Fir trees on my property, so I selected three of them, two with 12-inch diameter bases and one of about 8 inches. I trimmed the top off the two larger trees at a point where they were about five inches thick. This gave me two poles approximately 80 feet long. Since I was only going to support a wire vertical, I topped the smaller tree at a point where it was roughly two inches thick. This gave me a pole 60 feet long. I was trying to have the cross-sectional area at the top of each large pole roughly equal to the area at the base of the smaller pole when they were overlapped.

The next step was to drag the poles to the antenna site and assemble the A-frame shown in Fig 9:

1. I bought a large, used railroad tie and cut it in half at the middle of its length. I then buried each half vertically with about 18 inches above the ground to form a pivot post. I placed the posts about 10 feet apart.

2. I placed the two large poles, side-by-side, midway between the two posts.

3. I placed the smaller pole on top of the two large poles—overlapping by about five feet—and lashed the three poles together using #9 galvanized smooth iron fence wire as indicated in Fig 9C. To begin the lashing, I stapled the end of the wire; as I applied each turn, I tightened it with a claw hammer. After 15 turns or so, I stapled the free end.

4. I then spread the butt ends of the large poles out to the pivot posts. [Did you use a team of mules, or just your burly "pecs"?—*Ed.*] This spreading tightened the lashings very nicely (!) so that the three poles were solidly connected.

5. I wanted to raise and lower the A frame at will and keep the pole ends away from soil contact (rot!). Therefore, I created a pivot at each post by drilling a 2-inch-diameter hole through

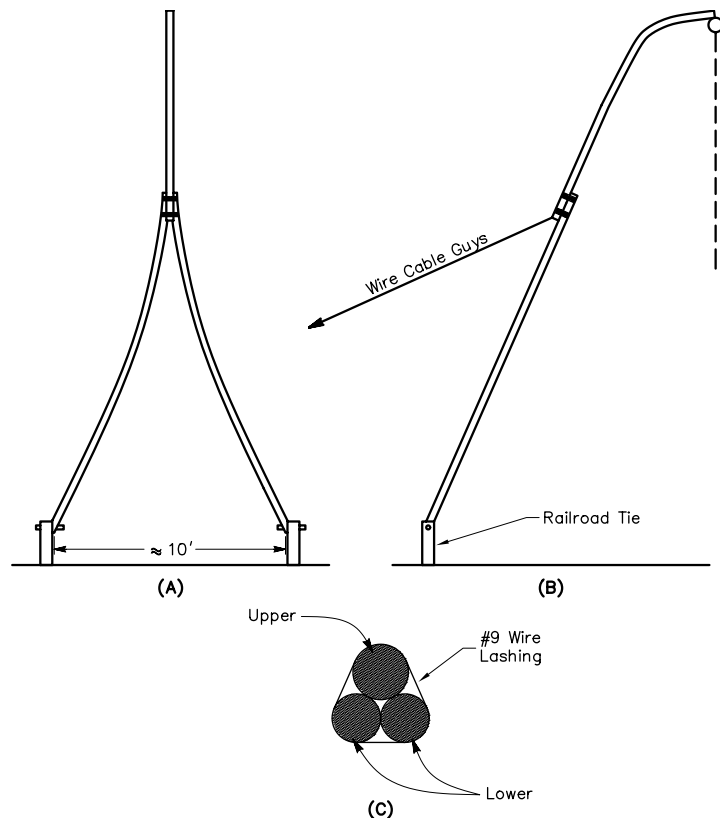

Fig 9

the post and pole butt. I then inserted a length of 1.5-inch galvanized iron water pipe as the shaft for the pivot. To keep the pipe from slipping out, I put a pipe cap on each end as a retainer.

6. The next step was to attach *two* halyards (one spare, just in case!) to the top of the mast. I used two small pulley blocks—the kind typically used on sailboats—and then rove a length of black, sun-resistant, $3/8$ -inch Dacron line through each block. The lines were long enough to form a continuous loop reaching the ground, so I could hoist or recover the antenna at will.

7. Finally I erected the A frame. In my case, I used a nearby tree as a gin pole (suitably guyed!!) along with three steel blocks and a long length of wire rope. Hoisting power was supplied by a small tractor. I took great care because of the forces involved. The initial lift required a pull of over 1000 pounds and the A frame weighs over a ton. (Green trees are heavy!) If I were more patient, I could have allowed the trees to dry out (months!),

which would have greatly reduced the weight.

I choose not to raise the mast to a vertical position because I wanted the antenna and the loading structures to stand clear of the mast and any guys. As shown in Fig 9B, I left frame tilted about 15° from vertical and bent the top over like a fishing pole, so it is even farther out from the base. The green pole bent relatively easily, and the bend became permanent when the wood dried out.

I used two wire-cable back-guys, anchored at the junction of the poles, to hold the mast in place. Although the weight of the mast makes it unlikely it would blow over towards the guys, I use the spare halyard as a guy from the top of the mast in the opposite direction to the wire guys. This arrangement minimizes conductors in the near field of the antenna.

The cost of the entire exercise was less than \$75, and I expect to get many years of use from the mast. Of course, I had the trees, the tractor and the hoisting tackle, which kept the cost very low.

Table 1—Antenna Comparison at 3.510 MHz

| Antenna | <i>h</i> (ft) | <i>L</i> 1 = <i>L</i> 2 (ft) | <i>Z</i> _{middle} Ω | <i>Z</i> _{end} Ω | Peak gain (dBi) | Peak angle ° | Wire loss (dB) | 2:1 BW (kHz) |
|-----------------|---------------|------------------------------|------------------------------|---------------------------|-----------------|--------------|----------------|--------------|
| λ/2 | 137 | 0 | 91 | >5000 | +0.30 | 16 | 0.08 | 270 |
| Lazy-H | 120 | 4.4 | 96 | 1096 | +0.28 | 17 | 0.07 | 280 |
| Lazy-H | 100 | 10.4 | 94 | 384 | +0.12 | 19 | 0.07 | 280 |
| Lazy-H | 80 | 17.4 | 81.3 | 180 | -0.06 | 20 | 0.08 | 260 |
| Lazy-H | 69.8 | 21.6 | 71.2 | 127 | -0.07 | 21 | 0.09 | 240 |
| Lazy-H | 60 | 26.3 | 59.7 | 90.9 | -0.15 | 22 | 0.10 | 200 |
| Lazy-H | 40 | 38.3 | 33.7 | 40.8 | -0.38 | 24 | 0.16 | 140 |
| Lazy-H | 30 | 45.6 | 21.5 | 23.8 | -0.59 | 25 | 0.23 | 100 |
| λ/4 (2 radials) | 69.8 | — | — | 38.8 | +0.11 by-0.39 | 22 | 0.15 | 200 |
| λ/4 (4 radials) | 69.8 | — | — | 35.7 | +0.21 | 22 | 0.13 | 175 |

More Modeling

In the process of developing this antenna, a great deal of additional modeling was performed to explore the effect on performance of different loading arrangements. One of the more interesting variations was a symmetrically loaded, two-radial antenna called a Lazy-H vertical (see Note 6). This antenna is intended to be supported between two trees. The antenna is identical to that shown in Fig 3, except that L1 = L2. Table 1 gives a comparison between a full λ/2 vertical, a λ/4 ground-plane with two and four radials and the Lazy-H with different values of *h* (height of the vertical portion) varying from 120 down to 30 feet. Note that the λ/4 Lazy-H is within 0.3 dB of the four-radial λ/4 vertical and has greater bandwidth. If two supports are available, the Lazy-H is much easier to fabricate than the four-radial version, and has significant size in only two dimensions instead of three. I assumed #13 copper wire and average ground for the models. *Z*_{end} is the impedance at the junction of the vertical section's lower end and the lower radials. The bottom of all the antennas is assumed 10 feet above ground.

In the 160-meter example given earlier, the top loading structure was simply a pair of drooping wires led to anchor points near ground. The question arises as to the comparison between flat configurations, like that shown for the Lazy-H and the drooping-wire alternative. This question can be quickly answered by modeling an end-loaded dipole in free space with

two different configurations as shown in Fig 8. The modeling shows that the drooping wires must be lengthened to achieve resonance, the radiation resistance is significantly lower with drooping wires and the far-field pattern is essentially the same. From a practical point of view, the use of drooping wires greatly simplifies the structure, and has very little effect on the far-field pattern. It may reduce the efficiency of the antenna if the radiation resistance is lowered too much, however. This is the kind of trade-off information critical to a new design.

In general, modeling this class of antennas shows that peak gain and peak-gain angle primarily determined by ground characteristics and the height of the vertical radiator, *h*. The loading means has only a second-order effect on the radiation pattern. A variety of loading arrangements can satisfy a particular situation with little loss of performance—as long as we keep the radiation resistance high enough to control losses.

Conclusions

This article has advocated a different conceptual view of vertical antennas: They can be viewed as loaded dipoles close to ground. Changing the point of view makes it easier to recognize the wide range of options available for configuring a high-performance vertical to meet the needs of a particular site and set of limitations. To assess the many options, we need the help of software. Unfortunately, no available software package provides the desired computational capabilities. Users of any an-

tenna modeling software should be very careful when setting up the model and interpreting results.

Acknowledgement

In addition to the referenced papers, other workers in this field have pointed out the advantages of the point of view presented here. This idea is certainly not the author's creation, although I wholeheartedly endorse it. Moxon's work deserves careful reading. I am indebted to Dr. L. B. Cepek, W4RNL; Dick Weber, K5IU, and Grant Bingeman, KM5KG, for their comments and support.

Notes

- ¹Brown, Lewis and Epstein, "Ground Systems as a Factor in Antenna Efficiency," *IRE Proceedings*, June 1937, Vol 25, No. 6, pp 753-787.
- ²A. Christman, "Elevated Vertical Antennas for the Low Bands: Varying the Height and Number of Radials," *ARRL Antenna Compendium*, Vol 5, 1996, pp 11-18.
- ³A. Christman, "Elevated Vertical Antenna Systems," *QST*, Aug 1988, pp 35-42.
- ⁴R. Weber, "Optimal Elevated Radial Vertical Antennas," *Communications Quarterly*, Spring 1997, pp 9-27.
- ⁵L. Moxon, "Ground Planes, Radial Systems and Asymmetric Dipoles," *ARRL Antenna Compendium*, Vol 3, 1992, pp 19-27.
- ⁶R. Severns, "The Lazy-H Vertical Antenna," *Communications Quarterly*, Spring 1997, pp 31-40.
- ⁷J. Belrose, "Elevated Radial Wire Systems For Vertically-Polarized Ground-Plane Type Antennas," Part 1, *Communications Quarterly*, Winter 1998, pp 29-40; Part 2, Spring 1998, pp 45-61.
- ⁸D. Weber, "Technical Conversations," *Communications Quarterly*, Spring 1998, pp 5-7 and 98-100. □□